

WATER HEATERS



HOW TO SAVE MONEY, ENERGY AND RESOURCES

Water heaters are the second greatest energy consumers in Arkansas homes after space heating and cooling, accounting for 15% to 25% of the average household energy budget. Fortunately, there are several strategies to cut the amount of energy you use and still meet your hot water needs. These methods fall into two categories: reducing the amount of hot water you use, and making your water-heating system more efficient.

This booklet was designed to answer common questions about hot water systems and provide Arkansans with information on how to save energy and money. You will find information on saving water and energy, upgrading your current water heating system, and the various types of water heating systems available. Additionally, there are tips on what to look for in a new system and charts to help you determine the real cost of owning and operating a water heater.

CONSERVING HOT WATER

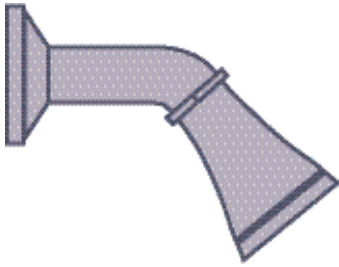

Figure 1

Showerheads

Water-saving showerheads use 2 to 3 gallons of water per minute. Conventional showerheads use 4 to 5 gallons per minute. Water-saving showerheads vary in feel from misty to needle-like to pulsating to vigorously pounding. In selecting a water-saving showerhead, it's important to find a model that fits your personal preference. Models with a shut-off button at the top of the head allow you to conveniently stop water flow while soaping up.

Using Less Saves You More

Your best opportunity to save energy is to use less hot water. In most households, the energy used to heat water can be reduced by 25% to 50% just by taking a few water-saving steps. In addition to saving energy (and money), cutting down on hot water waste helps conserve dwindling resources.

Water-saving Showerheads

The shower is typically the greatest consumer of hot water in a home. One of the easiest and most cost-effective steps you can take to cut hot water waste is to install a water-saving or low-flow showerhead.

You can determine whether your shower is a good candidate for a new showerhead with the help of a 1-gallon bucket and a watch with a second hand. First, turn on the shower to the pressure you normally use. Next, hold the bucket under the shower and time how long it takes the water to reach the 1-gallon mark. If it takes less than 20 seconds, your flow rate is over 3 gallons per minute (gpm), and you should replace it with a water-saving showerhead.

Water-saving showerheads use 2 to 3 gpm while conventional showerheads use 4 to 6 gpm. Switching showerheads can yield big savings. For example, if you replace a conventional showerhead that had a flow of 5 gpm with a water-saving showerhead using 2.2 gpm, you could be saving 2.8 gallons of hot water each minute you shower. This may not seem like a big savings, but those gallons can add up. Within a year a family of four, each taking a daily five-minute shower, could save as much as \$200 and over 20,000 gallons of water.

When buying a water-saving showerhead, shop carefully. Look for showerheads that use no more than 2.5 gpm at standard residential water pressure, and be sure to buy a quality product that doesn't simply restrict the water flow. A fine, misty shower won't make anyone happy.

There are also water-saving showerheads on the market that have quick shut-off buttons. These showerheads allow you to stop the water flow while you are lathering or shampooing your hair without changing the temperature settings. Water-saving showerheads will vary in cost from \$10 to \$40 and can pay for themselves in as little as four months.

Showers vs. Baths

A bath generally uses more hot water than a shower, taking approximately 15 to 25 gallons of hot water. A shower takes 10 to 15 gallons. You can compare the amount of water used in a shower to a bath by closing the drain before showering. If your tub is less full after a shower than it would have been after a bath, then you can save hot water by showering.

If it's just as full, or even fuller, you may want to stick to baths or take shorter showers.

Faucet Aerators

By installing faucet aerators at sinks in bathrooms, the utility room and the kitchen, you can reduce water flow to a more effective and usable level.

A conventional faucet will deliver 2 to 4 gpm while faucet aerators can reduce that amount to .5 or 1 gpm. In the kitchen you may want a higher flow rate of 2 to 4 gpm if you regularly fill the sink for dishwashing. However, if you tend to run the water when rinsing dishes, the .5 gpm flow is probably a good idea. Some models are sold with a convenient shut-off valve at the aerator that allows you to temporarily turn off the water without changing the hot/cold water mix. Sink aerators cost just a few dollars and easily pay for themselves in a short period of time.

If your home has unusually high water pressure, you may want to consider installing a *pressure-reducing valve* that can slow the water flow by 20% to 50%. The valves themselves cost about \$50 to \$60; however, we recommend that you pay a plumber to install it. Reducing the pressure will not only save water, but will also help limit any existing water-hammer problem in your plumbing.

Leaks

Leaky hot water faucets waste water, energy and money. A hot water leak that fills a cup in 10 minutes will waste over 3,000 gallons of hot water in a year. Many leaks can easily be repaired by simply replacing the faucet washer. Occasionally, the valve-stem packing is leaking and may also need to be replaced.

Some faucets in older homes will continue to leak even after the faucet washer and packing has been replaced. This is most likely because the valve seat that the washer presses against has become worn and pitted. In some cases, the valve seat should be replaced.

Many modern fixtures are more difficult to repair than older standard designs. For complex tasks, it is best to consult a household plumbing repair manual or hire a plumber to make the repairs.

Relief Valve Leak

The pressure-relief valve on top of your hot water tank can be another source of expensive leaks. If the drain pipe connected to this valve is warm over its entire length, your valve is leaking. Before replacing the valve, first try to flush it out by moving the control lever attached to the valve. This will sometimes flush out sediment stuck in the valve. If this doesn't work, you will probably need to hire a plumber to install a new pressure-relief valve.



Other Hot Water Saving Tips for the Bathroom

- When filling the bathtub, do not let the water run down the drain until it gets hot. Close the drain immediately and adjust the temperature as the tub is filling.
- When shampooing, turn off water while lathering.
- Rinse razors in a filled sink, rather than under a running faucet. An average of 20 gallons of water is lost down the drain when the water is left running while shaving.
- Wash your hands with cool water rather than hot.
- Turn off the tap while brushing your teeth.

Cost per drip of a leaking hot water faucet:

Drops Per second	Electric \$/month	Gas \$/month
0.5	\$2	\$1.15
1.0	\$5	\$2.50
1.5	\$8	\$4.10
2.0	\$11	\$5.60

Based on \$0.10 per kWh (kilowatt-hour) of electricity and \$1.00 per therm of natural gas.



Energy Saving Tips to Improve the Efficiency of Your Dishwasher

- Use all the energy-saving features for each load. Energy-saving wash cycles use less hot water. Also, the air-dry feature saves electricity because the heating coil is not working during the dry cycle.
- Run the dishwasher only with full loads.
- Don't pre-rinse; just scrape dishes by hand. If you only run the dishwasher every two or three days, pre-rinsing with cold water may be necessary.
- Turn the dishwasher off at the start of the dry cycle, open the door and let the dishes air dry.
- Install pipe insulation on your hot water pipes leading from the sink to dishwasher.



Energy Saving Tips for Your Laundry

- Unless you have a low-volume setting, run the washer only if you have a full load.
- Use a warm-wash/cold-rinse setting on your washing machine. This can save approximately 65% of the energy you would use with a hot-wash/warm-rinse setting.
- For clothes that are heavily soiled, treat the stained areas before loading. Note that hot water may be necessary to remove perspiration and oily stains from synthetic fabrics.
- Always use cold water for the rinse cycle. To ensure the best results carefully follow the cold water detergent instructions.

The Hidden Leak

You may also have hidden leaks. You can discover them by performing this simple test. First locate the two pipes coming out of the top of your water heater. One supplies the cold water to the tank and the other is the hot water outlet. When the hot water has not been in use for a few hours, the temperature of the two pipes will equalize. Feel both pipes. If temperatures are unequal, repeat the test after a few more hours, making sure not to use any hot water in the meantime. If both pipes are equal in temperature, you do not have a hot water leak. However if only the hot water outlet is still warm, you do have a leak. The pipe will be warm all the way from the tank to the location of the leak.

Dishwashers

In most homes, the two major water-consuming appliances are the washing machine and the dishwasher. Conventional automatic dishwashers use about 10 to 16 gallons of water per load while newer, energy-efficient dishwashers use as little as 5 gallons per load.

Use the proper type and amount of detergent, and store it in a cool, dry place (not under the sink). Moisture in detergent results in caking and may cause the detergent to leave a film on dishes.

You also may want to consider purchasing a new, high-efficiency dishwasher. Shop around for the most energy-efficient models; they generally use less water. Two features to look for are a short cycle and an air-dry option.

Depending on how careful you are, washing dishes by hand may or may not use less water than automatic dishwashers. To conserve water, use a sink stopper or dishpan, run the hot water as little as possible and when practical rinse the dishes in cold water.

Washing Machines

Washing machines are the second greatest hot water consumer in a home. A standard size clothes washer uses about 25 gallons of hot water for the hot-wash/warm-rinse cycle, and a large capacity washer can use as much as 40 gallons of hot water.

If you are in the market for a new washing machine, shop for one that has water and energy-saving features such as water-level and temperature controls. A large capacity tub can be useful because it is more efficient and easier to do a few large loads than several small ones. Also, you may want to consider a front-load model because it uses less water than a top-loading model. Finally, use the EnergyGuide label (Page 9) posted on new machines to help you determine the efficiency of each model.

VOLUME OF HOT WATER PER WASHLOAD (gallons)

Washer Settings	Standard Tub	Extra Large Tub	Front Loading Tub
hot wash/warm rinse	24	30	12
hot wash/cold rinse	16	20	8
warm wash/warm rinse	16	20	8
warm wash/cold rinse	8	10	4

UPGRADING YOUR CURRENT WATER HEATER

Increase Your Water Heater's Efficiency

In addition to cutting the demand for hot water, there are a number of steps you can take to improve the efficiency of your existing hot water system. The following is a checklist of energy-wise steps you can take. Details about each of these steps can be found in this section.

- Add a water heater blanket.
- Insulate the pipes.
- Lower the water temperature.
- Install a heat trap.
- Adjust the burners (gas).
- Drain the rust and scale.
- Insulate the bottom of your tank (electric).

Water Heater Blankets

One of the most energy efficient improvements you can make is to wrap an insulating blanket around the tank of your water heater. An insulating blanket will reduce *standby heat loss* — heat lost through the wall of the tank — by 25% to 45%. Insulation blankets are easy to install, and their cost (a mere \$10 to \$25) will be recouped within a year. A blanket with an insulation value of at least R-11 is recommended.

Make sure you buy an insulation blanket designed for your type of water heating system. With gas heaters, take special precautions not to block the air intake opening and to keep the insulation from touching the flue. This is essential for the heater to function properly and to avoid a fire hazard.

Many new water heaters come with very high insulation levels, reducing the economic advantages of adding an insulation blanket. In fact, some super-insulated models recommend not adding a blanket, so double-check the manufacturer's recommendations as the blanket may void the warranty in some cases. Insulation blankets can be found in hardware and home stores.

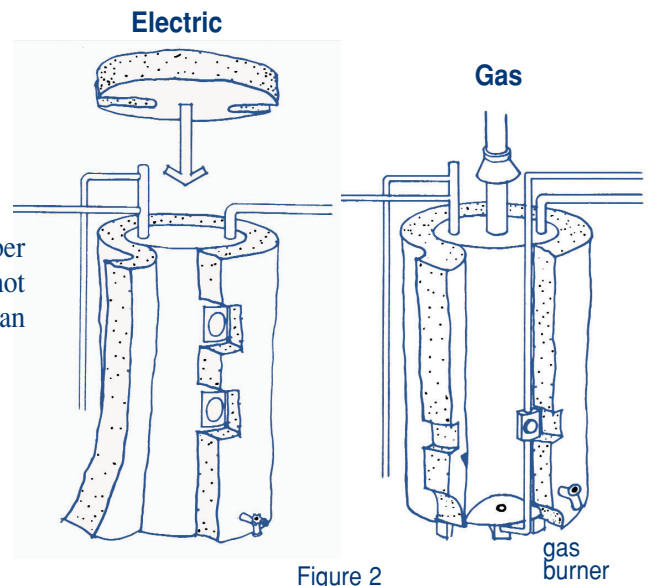

Adding a blanket to your hot water tank is an easy do-it-yourself job that can save you money on water-heating bills. Be careful not to insulate too close to intake or exhaust vents on gas water heaters, and keep the controls and thermostat accessible and uncovered on all models.

How Hot is Your Water?



In almost all cases, a hot water temperature greater than 120° F is not necessary and should be reduced for following reasons:

- The greater the water heater temperature, the faster the system will lose heat.
- Higher temperatures increases the rate of corrosion on internal fittings and other surfaces.
- Hot tap water is a scalding hazard, especially to children and seniors. Scalding occurs in two seconds at 150° F, while it takes 10 minutes to be scalded by 120° F water.



To Drain Your Water Heater

1. Shut off the water heater and allow the tank to cool.
2. Close the cold-water supply valve or shut off the water at the meter.
3. Open a hot-water tap in the house.
4. Open the drain valve and drain the tank until the water runs clear. If the valve is clogged, remove the stem and insert a small wire through the valve into the tank to get the water flowing.
5. Close the drain valve and open the cold-water supply valve. Do not close the hot water tap until all the air is exhausted from the tank and water flows from the tap.

Insulating Pipes

A great deal of energy and water is wasted while waiting for the hot water to reach the tap. Insulating your hot-water pipes will reduce heat losses as the hot water flows to your faucet, and it will reduce standby losses when the tap is turned on more than once within an hour. Even with insulated pipes, the water will eventually cool, but it will stay warmer longer than it would if the pipes were not insulated.

If your home meets any of the following criteria, it is a good candidate for pipe insulation: you use water frequently throughout the day; the water-pipe runs are long; or the pipes pass through an uninsulated crawl space or basement. For the best freeze protection in a crawl space or basement, wrap hot- and cold-water pipes. Pipe insulation comes in different forms: closed-cell flexible foam tubes (R-3 to R-5), rigid foam (R-7), and fiberglass batts (R-2 to R-3).

Lower the Water Temperature

For most households, a temperature of 120°F (halfway between the “low” and “medium” settings on most water heaters) will meet your hot water needs. This is well below the typical setting of 140° to 150° F. Each 10° F drop in temperature will generally save 3% to 5% on water heating costs. So, by setting back the thermostat to 120° F from 150° F, the system’s energy demand is reduced by 15%. Note that not all households can implement this measure, due to an automatic dishwasher without a booster heater or the need for a very large amount of hot water.

Electric water heaters often have two thermostats — one for the upper heating element and one for the lower heating element. These should be adjusted to the same level to prevent one element from overloading and wearing out prematurely. Before removing the access panels on an electric water heater, remember to turn off the electricity at the circuit breaker to avoid electrocution hazard.

Finally, when going away on long trips, turn the thermostat down to the lowest possible setting, or better yet, turn the water heater off. If you have a gas water heater, you may not want to turn your water heater off if you don’t feel comfortable relighting the pilot light.

Heat Traps

Metal is an excellent conductor of heat, and both hot and cold pipes offer a thermal shortcut for escaping heat. This phenomenon is easily observed by placing your hand on the cold and hot water pipes leading from your water heater at varying distances from the tank. Both pipes are usually warm, a sure sign of unwanted heat loss.

Heat is carried out of the tank by the movement of hot water, even when none is being drawn out of the taps. Hot water is buoyant, so it tends to rise in any vertical pipe, such as the hot water feed line. That hot water then releases its heat to the air surrounding the pipe until it

cools and sinks back down into the tank. This is called a *convection loop*, and it should be eliminated whenever possible.

The best way to prevent convection loops is to install heat traps and pipe insulation on the first few feet leading out of the tank. The simplest heat trap is a small *one-way valve* that can easily be inserted where the pipes enter the tank. The one-way valve prevents the cooling water from settling down again into the tank and being replaced by hot water.

A *360° loop* is another device to stop convection loops, but the one-way valve with insulation appears to save the most energy. Heat traps cost about \$30 and are best installed when the water heater is being replaced. A heat trap can save nearly as much as a blanket, and while it is easiest to install when replacing a heater, the savings are large enough to justify adding one to your existing system.

Adjust the Burners (gas)

A gas water heater should have a clean blue flame. If it doesn't, or if the pilot flame is over 1 to 1.25 inches long, it may need adjusting by a qualified service person.

Drain Rust and Scale

Sooner or later, rust and scale will build up inside the heater's tank. As the tank cycles through hot and cold periods, it expands and contracts, causing most of the rust and scale to drop to the bottom of the tank rather than stick to the tank walls. To remove the rust and scale, the bottom foot of water should periodically be drained from the tank. (See page 6 for step-by-step instructions.)

Insulate the Bottom of the Tank

If you have an electric water heater and it is stored in the basement, you should insulate the bottom of your water heater tank by setting it on a piece of thick styrofoam. The styrofoam will help reduce heat lost into the cold concrete floor. This measure may not be necessary, or recommended, for newer, super-insulated water heaters. Check your owners manual before adding the styrofoam.

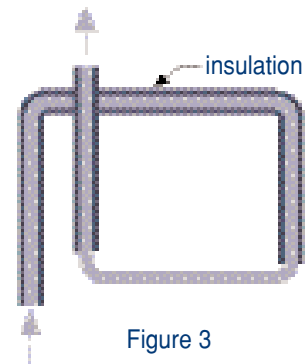

Figure 3

360° Loop Heat Trap

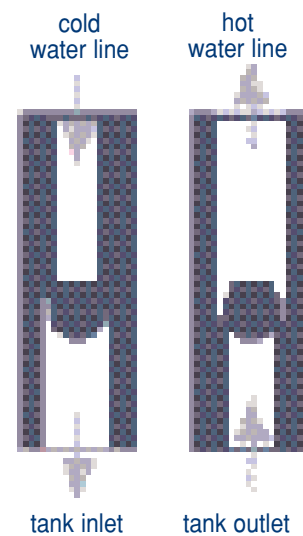

Figure 4

One Way Valve Heat Trap

BUYING A WATER SYSTEM

Buying a New Water Heater

Most people wait until their water heater breaks down before shopping for a new unit. Since they are in a hurry to restore their hot water supply, they usually don't take the time to shop for the unit that best

meets their needs. This situation can easily be avoided with a little planning. If the current water heater is at least seven years old, read this section carefully, evaluate hot-water needs and begin comparing the various types and models. Becoming familiar with the options today will allow a consumer to make an informed and energy-wise purchase tomorrow.

Even if the system is still working, it often makes sense to replace an inefficient water heater. The energy savings alone could pay for the new system within a few years.

What to Consider

The first factor to consider is your hot water needs and its relation to the *first hour rating* for peak hour demands of a system. FHR is also referred to as the ability of a unit to make a “quick recovery.” The FHR is the amount of hot water a unit can heat during a busy hour. This rating takes into account the tank size and how quickly cold water is heated. In some cases, a water heater with a small tank, but powerful burner, can have a higher FHR than one with a large tank and less powerful burner. Dealers can tell you the FHR of the water heaters they sell.

As the size of a tank increases, *the standby losses of the unit also increase because there is a greater tank surface area.* If the system is a large gas-fired unit, it will also lose heat up the flue. Therefore, before you shop for a new system, estimate your household’s FHR. Table A will help you calculate your hot-water need.

Table A only provides an estimate of your family’s hot water use for the busiest hour, not the amount of hot-water used in a day. The values in the table do not consider water conservation measures, like low-flow showerheads and faucet aerators that reduce hot-water use.

A rule of thumb to use in choosing a unit is that the quicker a unit can heat water, the recovery efficiency, the smaller the tank you will need. The longer it takes a unit to heat water the bigger the tank you will need. You may be able to reduce the unit’s size even further by making minor lifestyle changes like those mentioned earlier.

TABLE A: FIRST HOUR RATING/PEAK HOUR DEMANDS

Hot-water use	Avg. gal. hot water per usage	Times used in hour	Gal. used in hour
showering	15	x _____	= _____
bathing	20	x _____	= _____
shaving	2	x _____	= _____
washing hands & face	2	x _____	= _____
shampooing hair	4	x _____	= _____
hand dishwashing	2	x _____	= _____
automatic dishwashing	14	x _____	= _____
preparing food	5	x _____	= _____
automatic clothes washing	32	x _____	= _____
PEAK HOUR DEMAND (gallon used in hour)		TOTAL = _____	

*Source: Gas Appliance Manufacturers Association
The above chart assumes no water conservation measures

Look for Efficiency

Once you have determined the size of the unit needed, the next step is to decide which type and model is the most fuel efficient and economical. Some of the things to consider are:

- recovery efficiency (see below)
- energy factors
- first hour ratings
- tanks with at least 1.5 inches of insulation
- built-in heat traps
- energy source
- safety
- ease of operation and maintenance
- warranties

The unit's *energy factor* is the best indicator of a water heater's efficiency. The *energy factor* or *EF* is the overall measure of a heater's efficiency based on the following factors:

- *recovery efficiency* — how efficiently the heat from the energy source (i.e., gas, electricity) is transferred to the water;
- *standby losses* — the amount of heat lost through the tank walls and pipes;
- *cycling losses* — the extra energy expended in the starting and stopping of the burners (for gas only).

Use the EF rating when comparing systems with identical energy sources (e.g. gas compared to gas and electric compared to electric). The higher the EF rating, the more efficient the heater. The manufacturer's literature usually lists the EF rating, or it can be found on the yellow EnergyGuide® labels on the heaters.

It Pays to Compare

It may be tempting to simply buy the cheapest model and ignore operating costs, but this strategy will be costly in the end.

A helpful and reliable tool is the *EnergyGuide*® label displayed on water heaters and other major appliances. This label shows the yearly energy cost of operating an appliance and compares it to the energy costs of competing brands and models of a similar size and features. By considering the operating cost along with the purchase price, you'll be able to determine which appliance is less expensive to own and operate in the long run.

The type of *EnergyGuide*® labels found on water heaters are called *energy cost labels*. The large number in the center of the label is an estimate of the annual cost of the energy required to operate the appliance, based on a national average of electricity or natural gas rates. The bar beneath it shows the range of operating costs of competing brands and models of similar size and features. This allows you to quickly compare the model you are considering to others.

At the bottom of the label is a chart that allows you to determine more precisely what your cost to operate that appliance will be, based on your local utility rate. Appliance labeling was mandated by Congress as part of the Energy Policy and Conservation Act of 1975.

To find out more about specific brands of water heaters, you may contact the Gas Appliance Manufacturers Association listed in the Reference List (page 15) and request a copy of their *Consumers' Directory of Certified Efficiency Ratings*. Also, consumer publications and specialty magazines have product reviews that provide helpful and detailed information about various brands of water heaters.

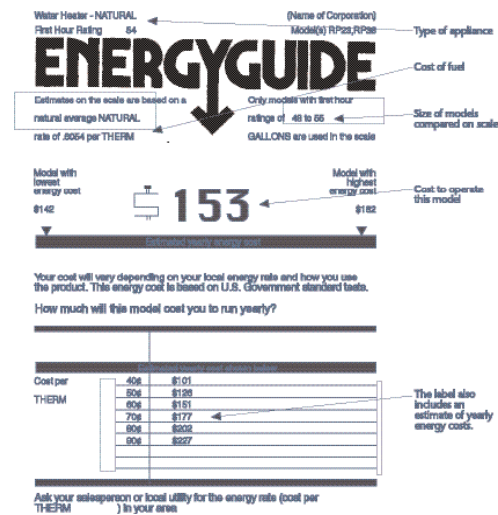

Figure 5

Sample Energy Guide Label

INSTALLING A WATER HEATER



Select an installation contractor carefully, making sure he or she has experience with the type of system you want. If the system you choose is integrated with your heating system, have your heating contractor put in the water heater. Though it may seem time-consuming, it is recommended to ask for bids from several contractors and evaluate the bids carefully, considering warranties, service, and reputation as well as cost.

The location of the water heater is important to the energy efficiency of the system. Storage water heaters will lose less heat if they are located in a relatively warm area. If at all possible, do not install the water heater in an unheated basement. Also, try to minimize the length of piping running to your kitchen and bathrooms. Ideally, the hot-water heater should be located near the hot-water tap most often used. That way, there is less chance of heat being lost through pipes while water is on its way to the tap.

When replacing a water heater, *heat traps* or one-way valves should be installed (if they are not already included in the unit) on both the hot- and cold-water lines to reduce heat loss through the water pipes. A more detailed description of heat traps can be found in the section of this booklet on improving efficiency. By following the general energy conservation tips listed in this booklet, your new water heater can be even more energy efficient.

TYPES OF WATER HEATER SYSTEMS



There are several types of water heating units available. The following section discusses the various types of systems on the market.

Storage Water Heaters

Storage water heaters are the most common type of water heater used in homes. They range in size from 10- to 120-gallons and are typically powered by electricity or gas (natural or liquid propane).

Figures 6 and 7 show typical electric-resistance and gas hot water heaters. Cold water from the service line flows in at the top of the heater, through an internal supply pipe to the bottom of the tank. The hot water exits through an outlet on top of the tank. A safety valve located near or on the top of the tank prevents overheating and excess pressure buildup, while a drain valve near the bottom of the tank allows it to be drained of rust and sediment. The tank is surrounded by a blanket of insulation and enclosed in a sheet-metal or non-metallic jacket. A magnesium anode hung in the water helps prevent tank corrosion.

Storage tank systems work by heating the water in the insulated tank. When the tap is turned on, hot water is pulled from the top of the water heater and cold water flows into the bottom to replace it. The cold water activates the thermostat, turning on the heat source. Electric units normally contain two heating elements, while gas-fired tanks have a burner at the bottom of the tank and the gas products of combustion exit up the chimney through an internal flue. When the proper temperature is reached, the heat source turns off.

The Choices

There are two choices of storage water heaters you can purchase: electric-resistance and gas (natural or liquid propane). Electric units generally require 240-volt service, while gas units require a gas line or propane tank. Both types have their pros and cons, which should be considered before buying.

Electric-Resistance Heaters

Electric-resistance models are comparatively inexpensive, as well as easy to maintain and relatively easy to install by a qualified service person. The EF ratings of electric-resistant water heaters can range from 70% to 97%. Electric units are also easy to turn off and on, and there is no need to worry about gas products of combustion or lighting a pilot. While electric units are more efficient, they can be more expensive to operate.

Gas Heaters

Gas water heaters are more expensive to buy and a qualified service person will need to install the unit. Also, because the gas products of combustion require a flue, their EF rating can range from 40% to 63%, and some super efficiency models rate as high as 80%. Even though they are less efficient than electric units, gas water heaters are generally cheaper to operate because of the relatively low price of gas. Gas units also can be used during power outages, which may be an advantage if the power in your area is subject to periodic blackouts. However, this advantage is lost if you have a power vented unit.

Liquid propane is generally more expensive than natural gas and typically used in more remote settings. Also, liquid propane is heavier than air and can be potentially dangerous if there is a gas leak in your unit. With natural gas units, there is also a danger of gas products of combustion being released into your home, so be sure the unit is vented properly. This is especially important if you have a super-insulated or air-tight house.

Utility costs differ, so it may pay to compare your local gas and electricity prices before making any decisions to switch water heater types.

Demand Water Heaters

Demand water heaters, sometimes called tankless, instantaneous or booster heaters, provide a continuous hot-water flow. Their simple design and small size make them ideal where there is limited space, such as in a mobile home or apartment. They are also easy to drain if freeze protection is a concern, such as with a summer house. Demand units are also good for high local use areas like hot tubs or Jacuzzi baths.

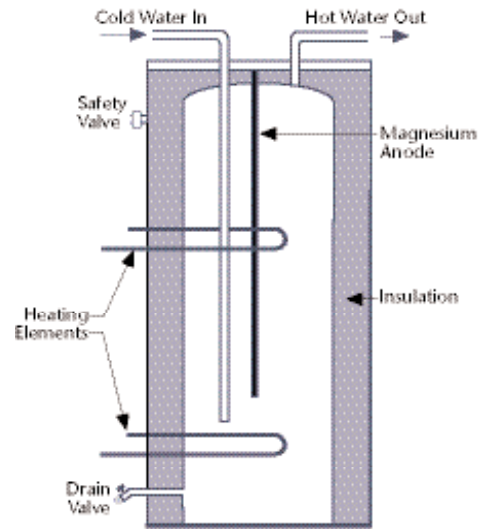

Figure 6: Cross section of a typical electric-resistance water heater.

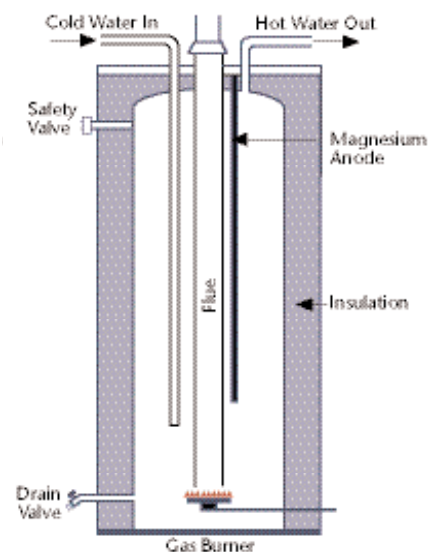

Figure 7: Cross section of a typical gas-fired water heater.

Demand water heaters are made up of a heat exchanger, a burner or electric element, and a control system that determines the water's output temperature and the flow rate. Demand water heaters have a simple design which makes them less likely to break down and easy to repair. Both natural gas and electric models are available, and they have a long life of 20 years, about twice that of conventional storage heaters.

Demand water heaters are rated according to the number of gallons of hot water they can produce per minute. Typically, gas units heat faster than electric units. The largest readily available gas-fired demand water heaters can supply from 5 to 6 gallons of hot water per minute with a temperature rise of 90° F. Therefore, if the incoming water temperature is 50° F and the desired temperature is 140° F, a rise of 90° F is needed. Some gas-fired demand water heaters have an energy-consuming pilot light. More efficient models have pilotless or electric ignition.

Some demand units heat water a set number of degrees regardless of the water flow rate or incoming temperature. This can cause dangerous overheating and problems with low water flows. Thermostatically controlled or modulating models are safer because they maintain a constant outlet temperature. Since these types of heaters raise the water to a specified temperature, the warmer the incoming water, the less work for the system.

Demand water heaters, however, usually cannot provide large amounts of hot water at the same rate as conventional water heaters. For instance, such a water heater could not provide enough hot water to use the washer, dishwasher and shower simultaneously. However, it could provide all the hot water needed if they were used in succession. Demand systems are also more effective when water-saving showerheads and faucet aerators are incorporated.

The major disadvantage of demand water heaters is the cost of purchasing and installing a unit. Prices for a large unit that can service a typical household range from \$550 to \$1,500. Depending on your family's size and water use, a demand unit could reduce your annual energy use and costs, but the *payback* of investing in a demand unit can be 12 years or more. *Payback* is when the cost of installing the unit is equaled in cumulative energy dollars saved.

Another drawback is that households using electric demand units may need to upgrade their electrical service since electric demand units draw large amounts of power in a short period of time.

Finally, demand water heaters are not widely used in this country. As a result, it may be difficult to find qualified professionals to install and service them. They may also pose a problem when selling houses because many home buyers will be unfamiliar with the operation and benefits of demand water heaters.

Demand water heaters make the most sense in vacation homes that are not used all the time and in households with small, easily coordinated hot water requirements. If you decide on a demand water heater, look for one with a feature called modulating temperature control. This feature provides constant-temperature water at different flow rates. Without it, you may be unhappy with fluctuating water temperatures.

Heat Pump Water Heaters

There are several innovative technologies on the market for heating water. These new systems range from units that can heat water by reusing the waste heat or exhaust from your air conditioner to systems that heat water using renewable energy.

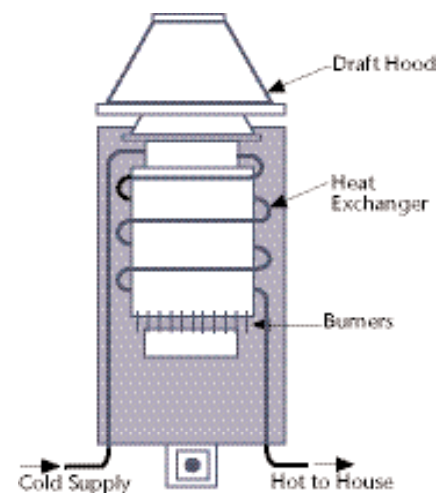

Figure 8: Components of a Demand Water Heater.

One new system that has become more widely used is the *heat pump water heater* or *HPWH*. These systems save impressive amounts of energy compared to other types of electric water heaters and have the added benefit of cooling and dehumidifying.

A HPWH works like a room air conditioner, except that it pulls or “pumps” the heat from indoor air into the water tank rather than releasing it outdoors (see Figure 9). While there are several types of HPWHs available, the most appropriate for residential and small commercial use is the air-to-water HPWH. Small capacity HPWHs release the cool air to the area surrounding the unit, while larger capacity HPWHs often distribute cooling to other spaces through a home’s ductwork.

There are two types of HPWHs: integral and add-on units. The integral or all-in-one unit has heat exchange coils immersed in a storage tank with the heat pump attached to the top of the tank. These units come with two small heating elements to assist the HPWH during periods of high hot-water use.

Add-on units consist of a heat pump that is connected to an existing hot-water tank. The heat exchange process occurs outside the tank in a small unit housing the heat pump. Since HPWHs cannot heat water quickly, one of the original electric heating coils in the hot water storage tank is usually kept in the retrofitted unit to allow for quick recovery.

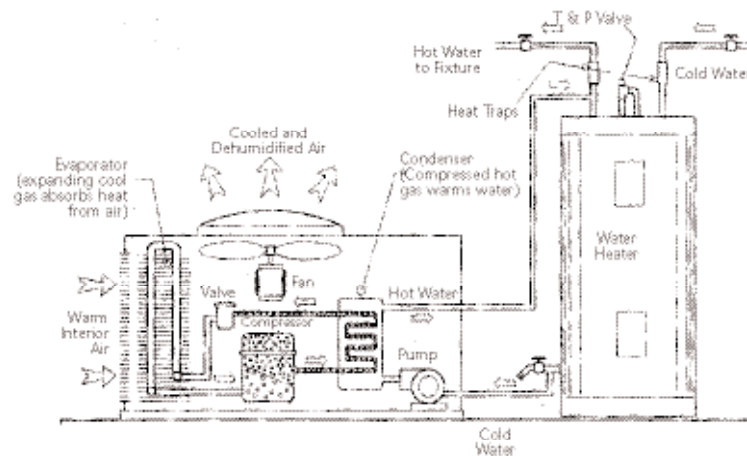

Figure 9: Heat pump water heater

Although most HPWHs operate in the combined mode, simultaneously providing water heating, cooling and dehumidification, several HPWH models can switch from the combined mode to the cooling-only mode when hot water is not needed. Another innovative use of HPWHs has been developed for use in tightly sealed residences where the system can be integrated with the building’s ventilation system. In these instances the HPWH can heat water while recovering heat from the ventilation system as it provides humidity control and fresh air.

Compared to conventional electric-resistance water heaters, HPWHs have a high initial cost: \$600 to \$800 for an add-on and as high as \$1,200 for an integral system. Installation cost for these systems can also vary greatly, so it pays to compare. HPWHs, however, can save significant amounts of energy and money (up to 50% of the electric water heating bill), and often recovers the system’s extra cost within several years, when compared to a resistance electric unit.

Multi-Function Water Heating

If you are considering replacing your furnace and/or air conditioner in the near future, you may want to consider a multi-function, full condensing water heating system. These units have refrigerant-to-water heat exchangers sized to fully condense hot refrigerant in a vapor compression system, allowing the unit to run in several different modes including:

- space cooling only,
- space cooling and water heating,
- space heating only,
- space heating and water heating, and
- water heating only.

Multi-function systems have two condensers: one for space heating or cooling and the other for water heating. These systems are referred to as “full condensing” because, unlike heat reclaiming units, they can apply 100% of the waste heat energy produced during the cooling mode to water heating. There are drawbacks to this system. For example, due to the all-in-one design of the multi-function system, water heating capability is lost if malfunctions occur elsewhere in the vapor compression system. It is recommended that an electric-resistance water heater be used as a back-up system.

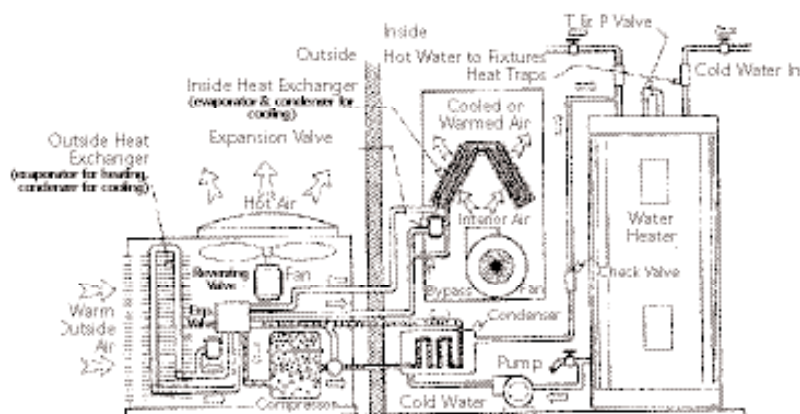

Figure 10: Multi-Function heat pump water heater

heat exchanger, a water pump and controls that recover heat (usually waste heat) for water heating. The refrigerant vapor is discharged from the air conditioner’s compressor in a “superheated” form and the desuperheater extracts this superheat and transfers it to the water (thus the name “desuperheater”).

Desuperheaters can heat water only if the air conditioner is operating. If the air conditioner is used five to seven months per year, a heat recovery unit could save 50% to 75% of hot water needs during the summer months. One characteristic of these units is that they work best with less efficient air conditioners and they end up increasing the operating efficiency of the air conditioner itself.

Before investing in a desuperheater, be sure the air conditioner’s warranty will not be voided by adding desuperheater equipment. Finally, this type of unit is not self-sufficient and requires a backup water heating source.

Solar

Solar water heaters use the sun’s energy rather than electricity or natural gas to heat water. Electricity is used to operate pumps, and electricity or gas is commonly used to provide backup heat during long periods of cloudy weather. Depending on the climate, a well-designed and properly-sized solar water heater can provide up to two-thirds of a household’s hot-water needs. The most widely used type of solar water heater system circulates water from a storage tank through one or more solar collectors and back into the tank. A controller regulates the circulating pump, turning it on when there is enough solar energy to heat the water. Another design is called a “batch” water heater, which is a solar-heated tank. No pumps are needed in this design; therefore no added electricity is used. While it is not as efficient as the collectors mentioned above, its low initial cost (can be built by the do-it-yourself builder), low operating cost (uses no electricity) and low maintenance cost make it a viable option.

A solar water heater can save 50% to 85% of the hot water portion of monthly electric utility bills if the backup element is kept at 122° F. A solar water heater can save even more if the backup system is turned off and the homeowner relies solely on the sun for hot water. A disadvantage of solar water heaters is that they are extremely costly to install. Additionally, solar water heaters are not widely used in Arkansas so be sure to find a qualified service person or dealer to handle installation and routine service and repairs.

Desuperheaters

If you place your hand on the outside of an air conditioner or in front of the vent of your refrigerator you can feel hot air. Desuperheaters, also known as refrigeration heat reclaim units, use the exhaust heat from cooling units, like air conditioners, to heat water. In a residential setting, when air conditioning is being used, desuperheaters can provide hot water at little or no cost and also improve the efficiency of the air conditioner.

A desuperheater is a unit that consists of a refrigerant-to-water

FOR REFERENCE OR MORE INFORMATION



Alternatives to Air as Heat Sources for Heat Pumps, Hot Water Energy Conservation; Energy Efficiency and Renewable Energy Clearinghouse (EEREC), Department of Energy, P.O. Box 8900, Silver Spring, MD 20907, 1-800-523-2929.

Conserving Water Indoors, Demand Hot Water, Home Hot Water, and Heat Pumps; Washington State Energy Office, Energy Extension Service, Energy Library, 809 Legion Way SE, P.O. Box 43165, Olympia, WA 98504-31656, 1-800-862-9731.

Gas Appliance Manufacturer's Association (GAMA), 1910 N. Moore St., Suite 1110, Arlington, VA 22209; 703-525-9565. Publishes informative materials and product directories.

Hot Water Energy Conservation, Saving Energy and Money With Home Appliances; American Council for an Energy Efficient Economy (ACEEE), 1001 Connecticut Ave., NW, Suite 535, Washington, D.C. 20036. Twice a year ACEEE publishes a guide to the top-rated appliances which can also be found at www.aceee.org/consumerguide/.

Solar Water Heating: A question and answer primer; Florida Solar Energy Center; 300 State Rd. 401, Cape Canaveral, FL 32920, 407-783-0300, www.fsec.ucf.edu.

This is an Iowa Energy Center publication.



2521 ELWOOD DRIVE, SUITE 124
AMES, IOWA 50010-8263
515-294-8819 • FAX 515-294-9912

This publication has been updated and modified for use in Arkansas by the Arkansas Department of Economic Development – Energy Unit.



ONE CAPITOL MALL
LITTLE ROCK, AR 72201
501-682-7319 • FAX 501-682-2703
WWW.1800ARKANSAS.COM/ENERGY/

This publication is distributed by:



Arkansas Department of
Economic Development
Energy Unit
One Capitol Mall
Little Rock, AR 72201



